

# Solaron® Remote PV Tie (RPT™) Accessory

*Reduce solar PV system installation costs and increase system efficiency even further*

## Benefits

- Increase PV system design and installation flexibility
- Cut PV BoS wiring costs
- Reduce installation labor
- Achieve higher system efficiency

## Features

- Enables PV inverter placement further from the arrays
- Eliminates neutral DC home runs
- Reduces resistive wiring losses
- Reduces wire size

*Advanced Energy® introduced breakthrough efficiency and reliability with the Solaron® line of commercial, grid-tie PV inverters—field-proven, bipolar, and transformerless. Now, with another truly innovative approach, we offer the Remote PV Tie (RPT™) accessory that eliminates common inverter installation obstacles to dramatically reduce BoS installation costs and help you achieve even higher system efficiency.*

Challenging issues for solar PV system designers include inverter placement and ever-increasing BoS installation costs. The Solaron® Remote PV Tie (RPT™) accessory expands conventional installation boundaries. Now you can install your Solaron inverter up to 2000' (609.6 m) from the PV arrays while minimizing cost and optimizing system efficiency.

### Reduce Solar PV System Installation Costs

Inverters that stand directly adjacent to solar PV arrays are ideal but in many cases not possible or optimal. The greater the distance between arrays and inverters, the more staggering the cost and the greater the DC cable losses. However, when you install the new RPT accessory near your arrays, inverter placement possibilities become virtually unlimited.

The RPT accessory connects the neutrals of the arrays together without returning to the Solaron inverter. Two conduits containing the hot wires

(positive and negative) connect the arrays to the inverter. Inexpensive 16 AWG wire connects the RPT accessory to the inverter. This eliminates the expensive, long-length and large-diameter wires of the neutral DC home-run legs, not to mention conduit and installation labor, which can amount to tens of thousands of dollars. When installed with Solaron inverters, the RPT accessory reduces the distance of DC transmission current twofold over conventional 600 VDC distribution.

### Achieve Higher Efficiency

During operation, conventional PV installations expend approximately 4% of energy production in resistive wiring losses alone. When you install one or more RPT accessories in the center of the arrays, you cut DC wiring losses in half. You can then position the inverter near the building entrance to reduce AC losses. The result is either higher total system efficiency or the opportunity to use fewer panels in your system installation for the same AC energy harvest.

With the Solaron® RPT™ accessory, you reduce BoS material costs *plus* gain efficiency.

Example PV System Installation with 500' (152 m) Between the PV Arrays and Solaron® Inverter		
	Conventional Inverter Installation	Installation with Solaron® RPT™ Accessory
Wiring Costs	2 x 500' of large diameter neutral wire = \$12,000	6 x 500' of 16 AWG wire = \$250
Efficiency Gain (Due to Reduction in Resistive Wiring Losses, $I^2R$ Loss)	0% efficiency gain	+2% additional efficiency or fewer panels required

## Specifications

Description	Specifications
Dimensions	24" (H) x 24" (W) x 12" (D) 61.0 cm (H) x 61.0 cm (W) x 30.5 cm (D)
Weight	90 lb (41.8 kg)
Enclosure	NEMA 3R stainless steel
Max MPP Current	500 A @ 333 kW 750 A @ 500 kW
Max Distance Between RPT™ and Solaron® Inverter	2000' (609.6 m)
Input Connector	4 x 500 MCM wire max for each array
Insulation	600 V insulation on control wiring
Operating Temperature	-40 to 122°F (-40 to 50°C)
Directives and Standards	NRTL certification to UL 1741-2005 by CSA International as an accessory to the Solaron inverter

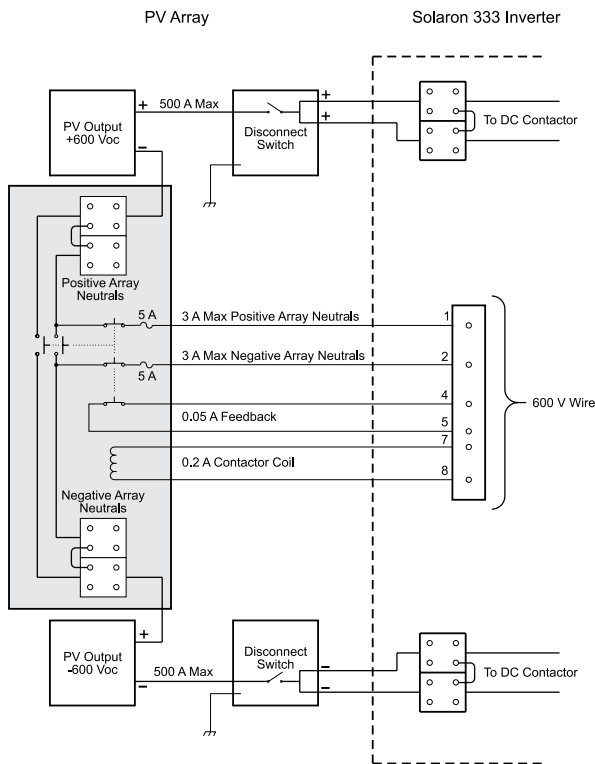

Figure 1. Solaron® RPT™ accessory wiring diagram

Specifications are subject to change without notice.



Advanced Energy Industries, Inc. • 1625 Sharp Point Drive • Fort Collins, Colorado 80525 U.S.A.  
T: 800.446.9167 or +1.970.221.4670 • support@aei.com • www.advanced-energy.com  
Please see [www.advanced-energy.com](http://www.advanced-energy.com) for worldwide contact information.

© Advanced Energy Industries, Inc. 2008  
All rights reserved. Printed in U.S.A.  
ENG-SolaronPV Tie-250-03 0M 10/08